

FE2owlet

FN071-SD_.6K_.7P1

Performance data

3~ 460V ±10% Δ/Y 60Hz

P_1	1.55/1.05	kW
I	2.8/1.6	A
n	1070/850	rpm
I_A	10/3.3	A
ΔI	0	%
t_R	70/158	°C/°F

Characteristic data

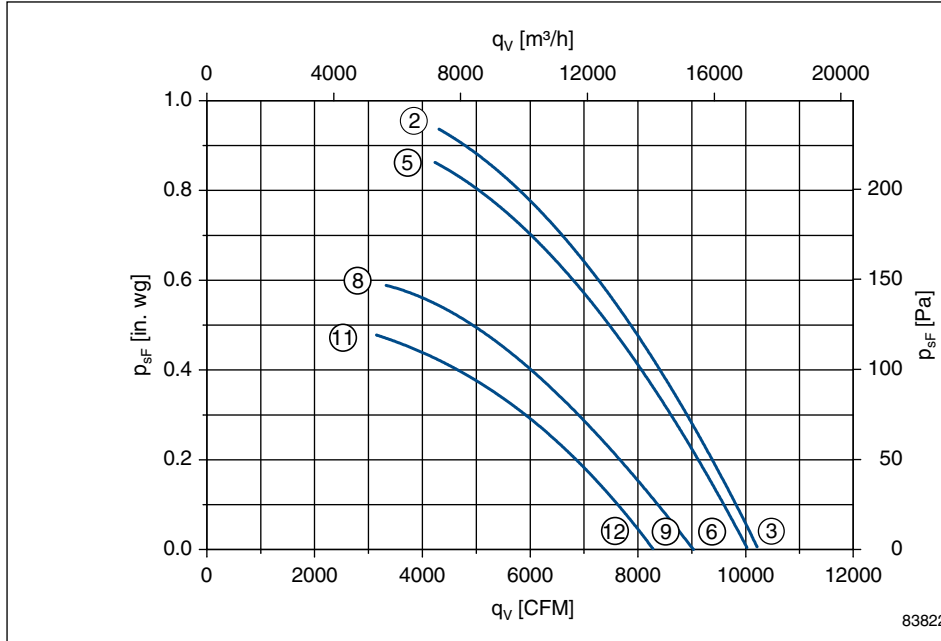

	U V	I A	P_1 W	n rpm
②	460	2.8	1550	1070
③	Δ	2.2	960	1130
⑤	400	2.7	1450	1030
⑥	Δ	2.0	900	1100
⑧	460	1.60	1050	850
⑨	Y	1.15	740	1000
⑪	400	1.55	900	770
⑫	Y	1.15	660	930

$$p_{dZ} = 2.9 \cdot 10^{-7} \cdot q_v^2$$

measured in full bell mouth without guard grille in installation type A according to ISO 5801

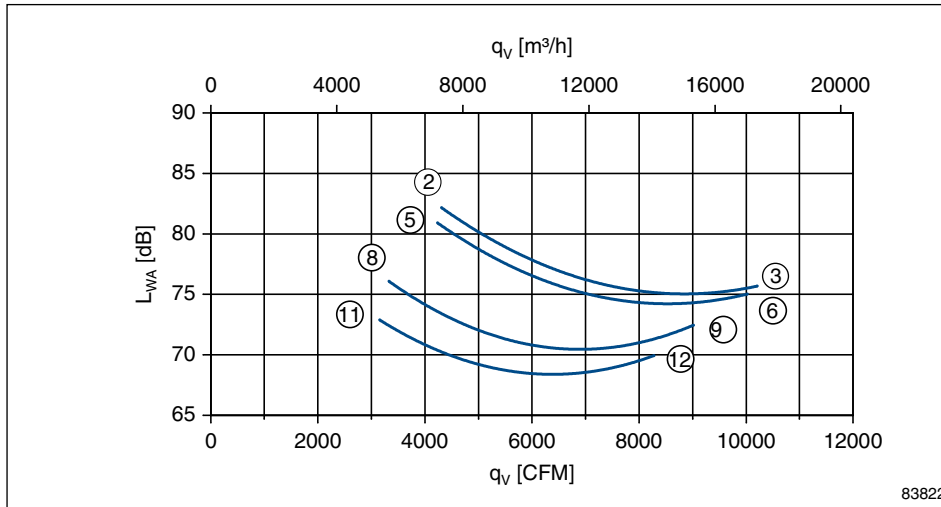

Dimension sheet

Type	Article no.	Design	Airflow direction	Weight		Connection diagram	Dimension sheet	Page
				kg	lbs			
FN071-SDA.6K.A7P1	153 131	A	A	21	46.3	108XB	L-KL-2751	70
FN071-SDD.6K.A7P1	153 132	D	A	24	52.9	108XB	L-KL-2752	71
FN071-SDQ.6K.A7P1	153 133	Q	A	35	77.2	108XB	L-KL-2753	72
FN071-SDA.6K.V7P1	153 134	A	V	21	46.3	108XA	L-KL-2754	73
FN071-SDK.6K.V7P1	153 135	K	V	30	66.1	108XA	L-KL-2749	74
FN071-SDQ.6K.V7P1	153 136	Q	V	38	83.8	108XA	L-KL-2756	76
FN071-SDS.6K.V7P1	153 137	S	V	27	59.5	108XA	L-KL-2755	75
FN071-SDF.6K.V7P1	153 138	F	V	37	81.6	108XA	L-KL-2750	77

FE2owlet

FN071-AD_.6F_.7P1

Performance data

3~ 460V ±10% Δ/Y 60Hz

P_1	0.74/0.41	kW
I	1.30/0.76	A
n	780/510	rpm
I_A	3.3/1.1	A
ΔI	0	%
t_R	70/158	°C/°F

Characteristic data

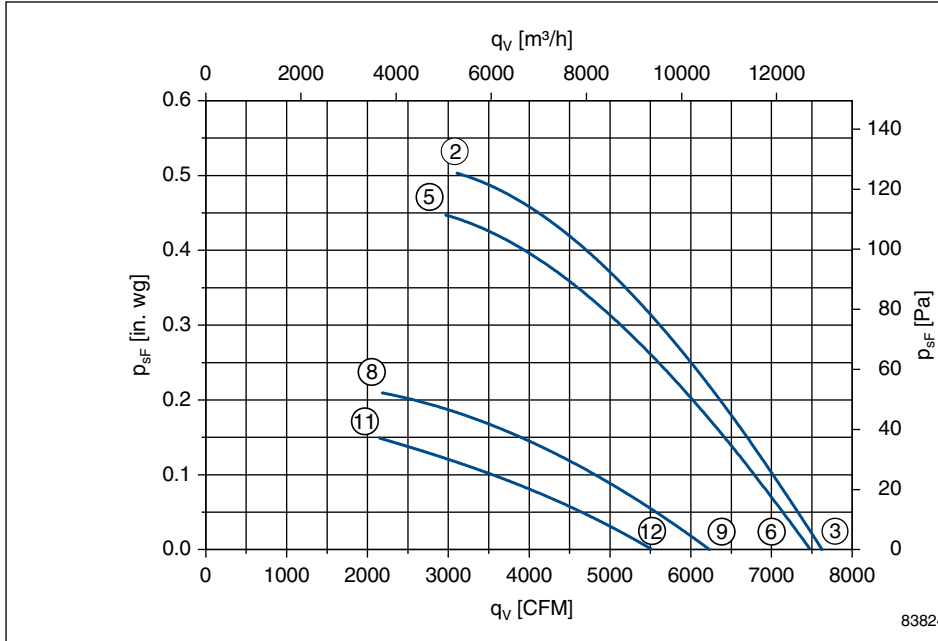

	U	I	P₁	n
	V	A	W	rpm
②	460	1.30	740	780
③	Δ	0.99	450	840
⑤	400	1.30	670	740
⑥	Δ	0.95	420	820
⑧	460	0.76	410	510
⑨	Y	0.58	330	690
⑪	400	0.70	320	440
⑫	Y	0.58	290	610

$$p_{d2} = 2.9 \cdot 10^{-7} \cdot q_v^2$$

measured in full bell mouth without guard grille in installation type A according to ISO 5801

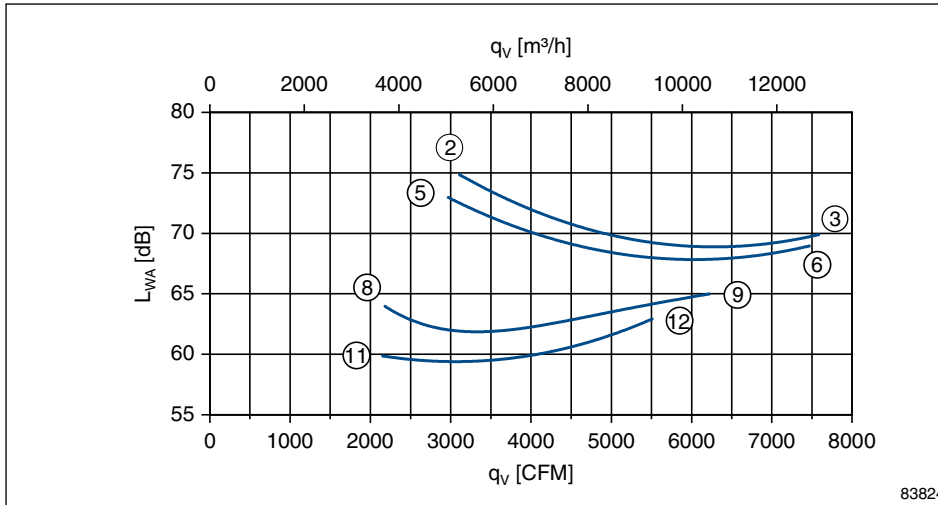

Dimension sheet

Type	Article no.	Design	Airflow direction	Weight		Connection diagram	Dimension sheet	Page
				kg	lbs			
FN071-ADA.6F.A7P1	153 139	A	A	17	37.5	108XB	L-KL-2751	70
FN071-ADD.6F.A7P1	153 140	D	A	21	46.3	108XB	L-KL-2752	71
FN071-ADQ.6F.A7P1	153 141	Q	A	32	70.5	108XB	L-KL-2753	72
FN071-ADA.6F.V7P1	153 142	A	V	17	37.5	108XA	L-KL-2754	73
FN071-ADK.6F.V7P1	153 143	K	V	26	57.3	108XA	L-KL-2749	74
FN071-ADQ.6F.V7P1	153 144	Q	V	34	75.0	108XA	L-KL-2756	76
FN071-ADS.6F.V7P1	153 145	S	V	23	50.7	108XA	L-KL-2755	75
FN071-ADF.6F.V7P1	153 146	F	V	33	72.8	108XA	L-KL-2750	77

FE2owlet

FN071-ND_.6F_.7P1

Performance data

3~ 460V ±10% Δ/Y 60Hz

P_1	0.25/0.14	kW
I	0.56/0.27	A
n	520/380	rpm
I_A	1.2/0.4	A
ΔI	0	%
t_R	70/158	°C/°F

Characteristic data

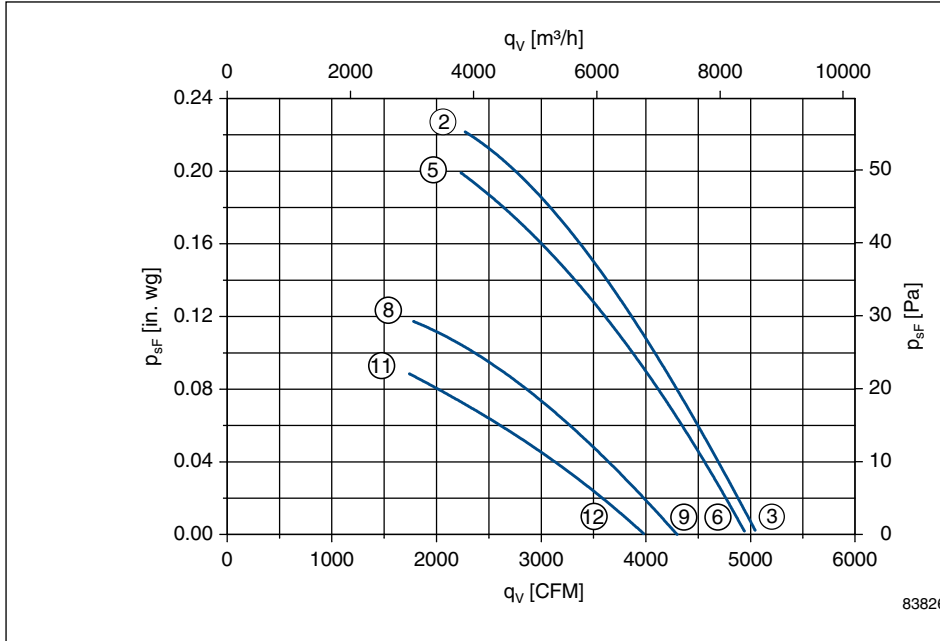

	U	I	P_1	n
	V	A	W	rpm
②	460	0.56	250	520
③	Δ	0.50	170	560
⑤	400	0.53	220	500
⑥	Δ	0.46	150	540
⑧	460	0.27	140	380
⑨	Y	0.22	110	480
⑪	400	0.25	115	340
⑫	Y	0.21	94	440

$$p_{d2} = 2.9 \cdot 10^{-7} \cdot q_v^2$$

measured in full bell mouth without guard grille in installation type A according to ISO 5801

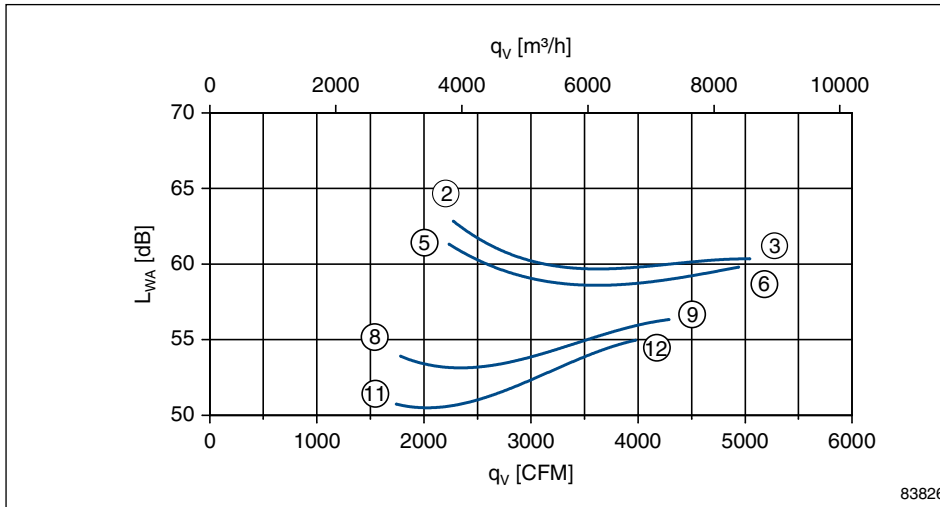

Dimension sheet

Type	Article no.	Design	Airflow direction	Weight		Connection diagram	Dimension sheet	Page
				kg	lbs			
FN071-NDA.6F.A7P1	153 147	A	A	17	37.5	108XB	L-KL-2751	70
FN071-NDD.6F.A7P1	153 148	D	A	21	46.3	108XB	L-KL-2752	71
FN071-NDQ.6F.A7P1	153 149	Q	A	32	70.5	108XB	L-KL-2753	72
FN071-NDA.6F.V7P1	153 150	A	V	17	37.5	108XA	L-KL-2754	73
FN071-NDK.6F.V7P1	153 151	K	V	26	57.3	108XA	L-KL-2749	74
FN071-NDQ.6F.V7P1	153 152	Q	V	34	75.0	108XA	L-KL-2756	76
FN071-NDS.6F.V7P1	153 153	S	V	23	50.7	108XA	L-KL-2755	75
FN071-NDF.6F.V7P1	153 154	F	V	33	72.8	108XA	L-KL-2750	77

FE2owlet

FN071- DA.6 A7P1

Airflow direction	A
Design	A
Material of impeller	Aluminium

**FN
071**

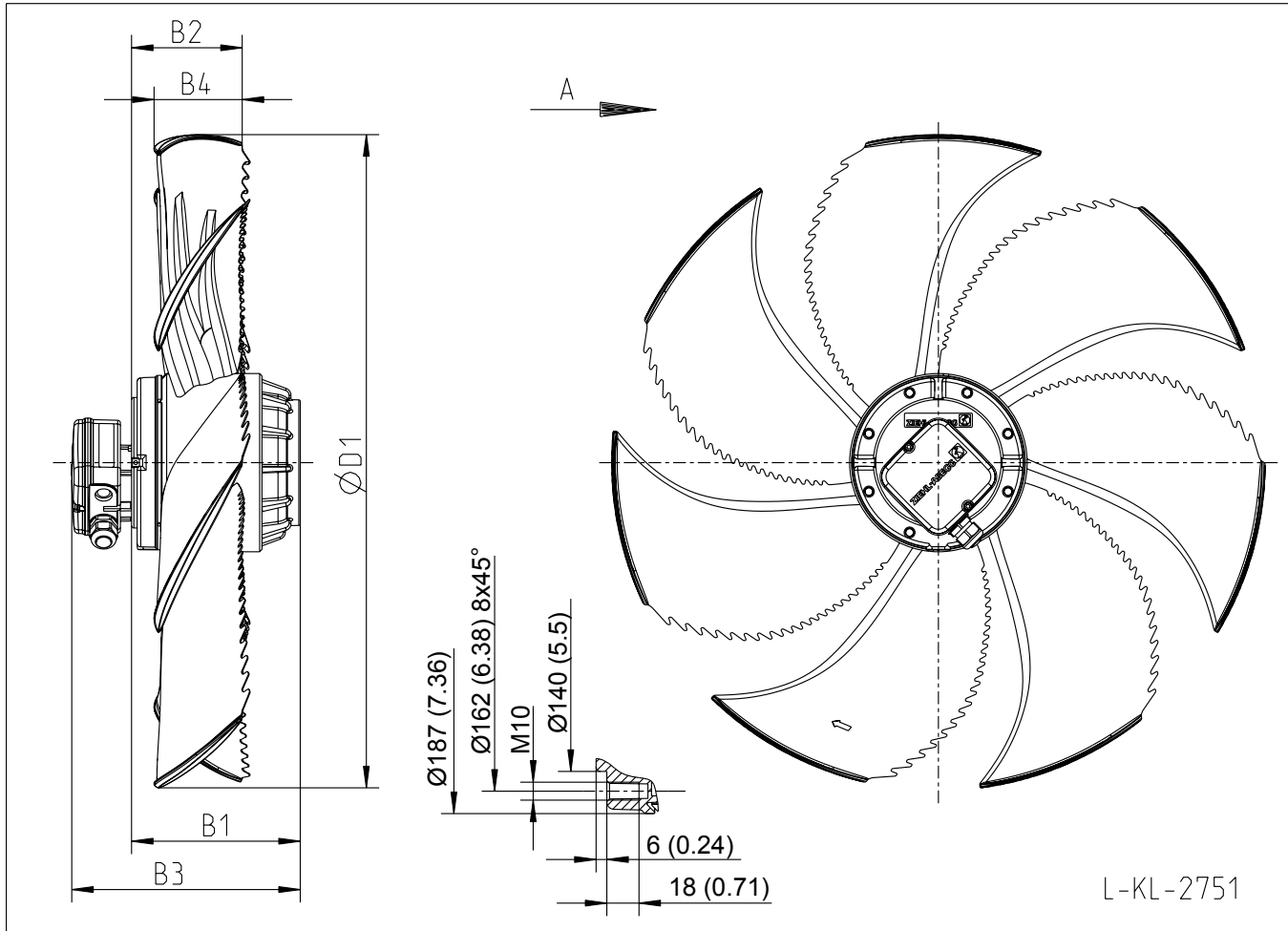

L-KL-2751

Type	Article no.	B1		B2		B3		B4		D1	
		mm	inch	mm	inch	mm	inch	mm	inch	mm	inch
FN071-SDA.6K.A7P1	153 131	182	7.17	119	4.69	246	246	95	3.74	703	27.68
FN071-ADA.6F.A7P1	153 139*	162	6.38	119	4.69	226	226	95	3.74	703	27.68
FN071-NDA.6F.A7P1	153 147	162	6.38	119	4.69	226	226	95	3.74	703	27.68

FE2owlet

FN071- DD.6 .A7P1

Airflow direction	A
Design	D
Material of impeller	Aluminium

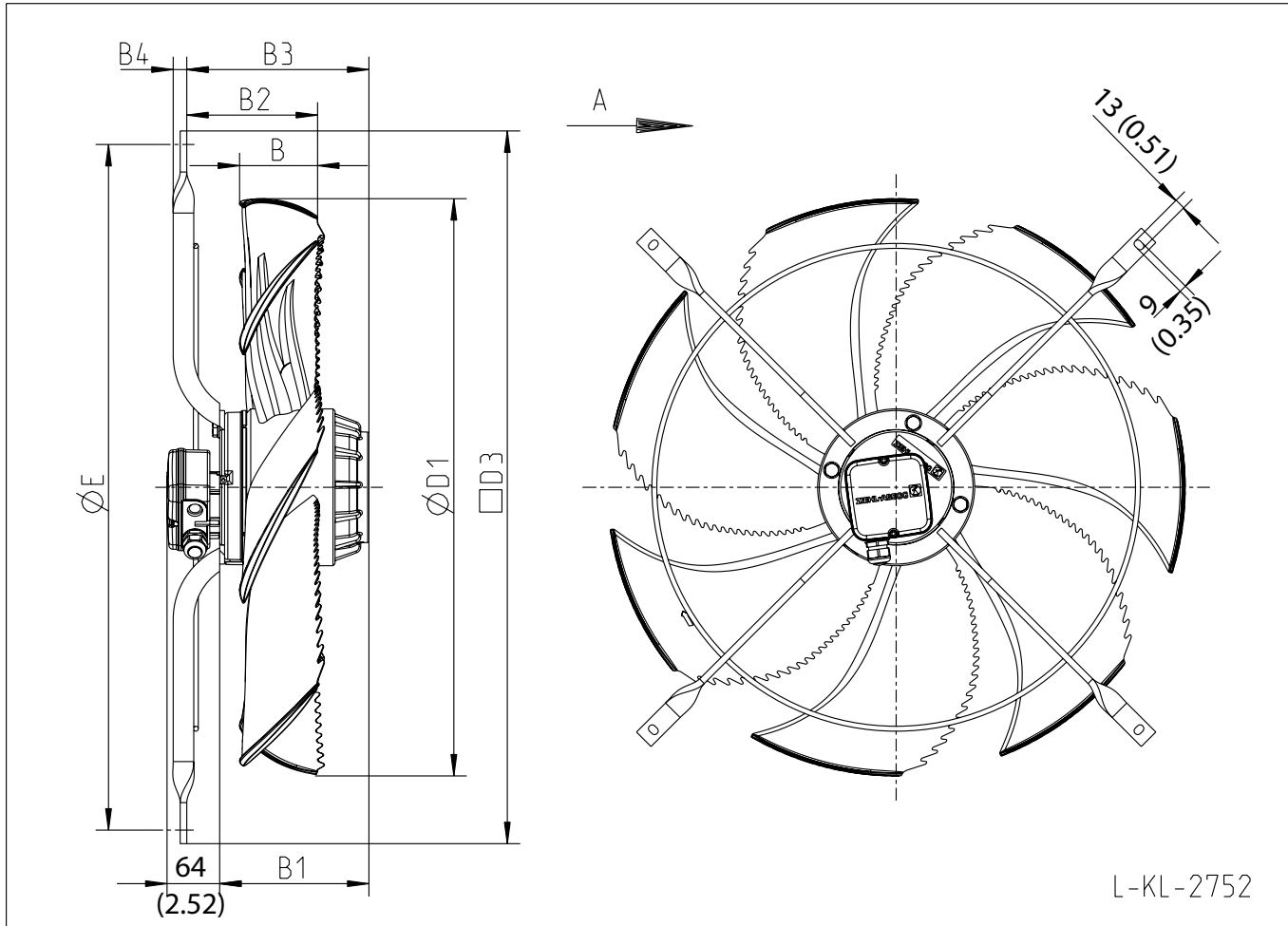

**FN
071**

L-KL-2752

L-KL-2752

Type	Article no.	B		B1		B2		B3		B4		D1		D3	
		mm	inch	mm	inch	mm	inch	mm	inch	mm	inch	mm	inch	mm	inch
FN071-SDD.6K.A7P1	153 132	95	3.74	182	7.17	159	6.26	222	8.74	16.5	0.65	703	27.68	868	34.17
FN071-ADD.6F.A7P1	153 140	95	3.74	162	6.38	159	6.26	201	7.91	16.5	0.65	703	27.68	868	34.17
FN071-NDD.6F.A7P1	153 148	95	3.74	162	6.38	159	6.26	201	7.91	16.5	0.65	703	27.68	868	34.17

FE2owlet

FN071- _DQ.6_ .A7P1

Airflow direction	A
Design	Q
Material of impeller	Aluminium

**FN
071**

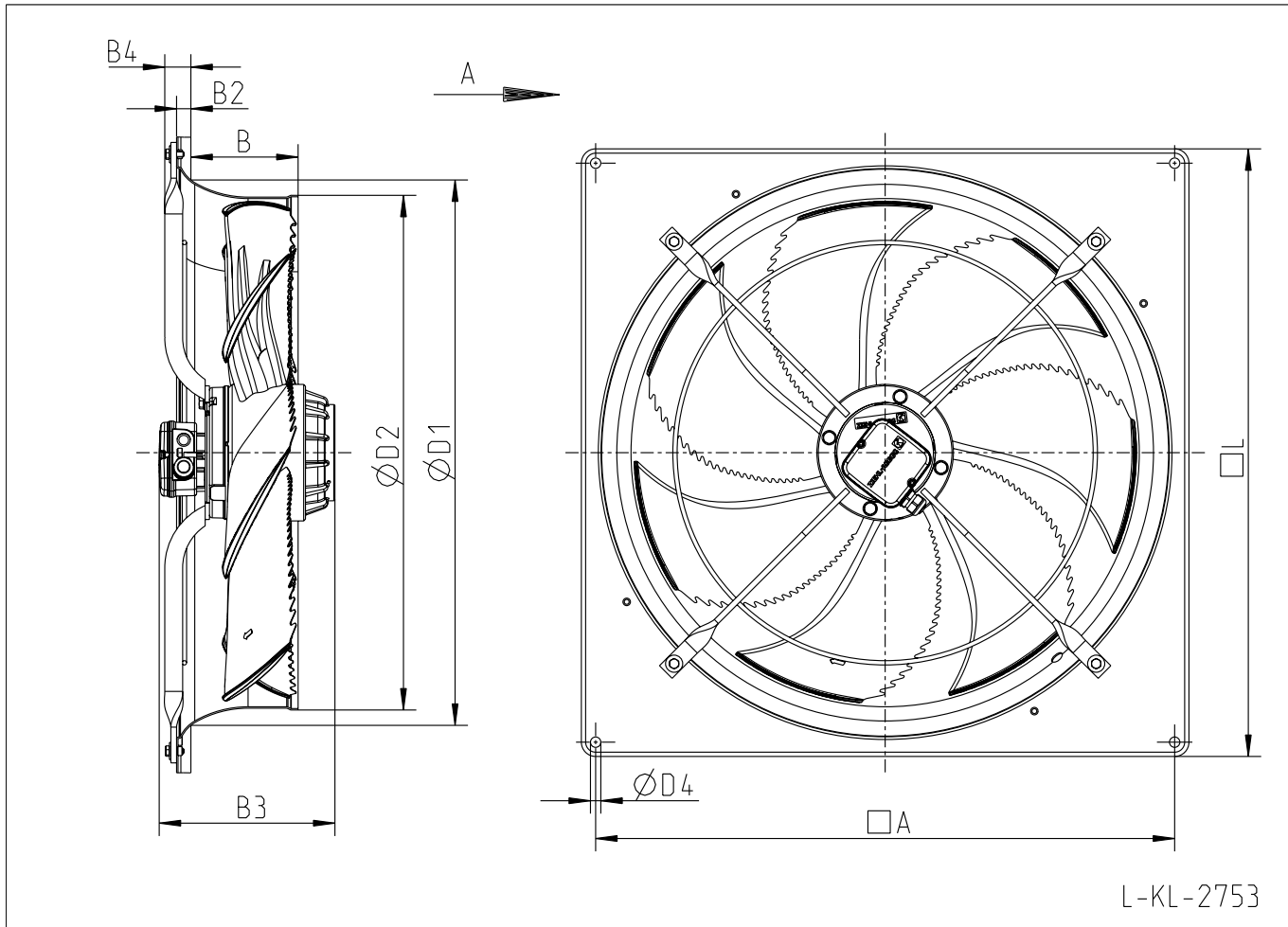

L-KL-2753

Type	Article no.	B		B2		B3		B4		D1		D2		D4		A		L	
		mm	inch	mm	inch	mm	inch	mm	inch	mm	inch	mm	inch	mm	inch	mm	inch	mm	inch
FN071-SDQ.6K.A7P1	153 133	150	5.91	20	0.79	246	9.69	37	1.46	763	30.04	720	28.35	14.5	0.57	810	31.89	850	33.46
FN071-ADQ.6F.A7P1	153 141	150	5.91	20	0.79	226	8.90	37	1.46	763	30.04	720	28.35	14.5	0.57	810	31.89	850	33.46
FN071-NDQ.6F.A7P1	153 149	150	5.91	20	0.79	226	8.90	37	1.46	763	30.04	720	28.35	14.5	0.57	810	31.89	850	33.46

FE2owlet

FN071- DA.6 .V7P1

Airflow direction	V
Design	A
Material of impeller	Aluminium

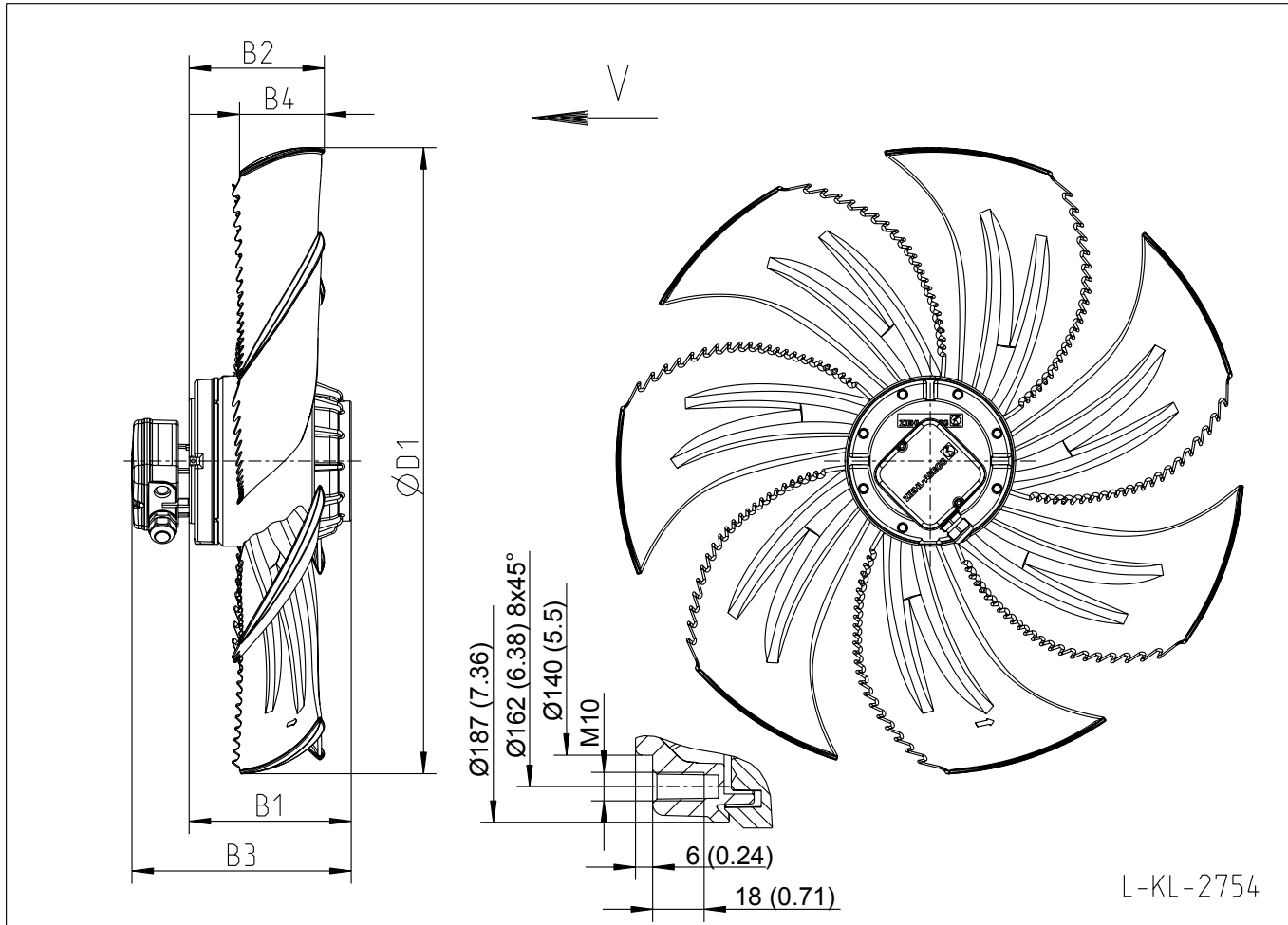

**FN
071**

L-KL-2754

Type	Article no.	B1		B2		B3		B4		D1	
		mm	inch	mm	inch	mm	inch	mm	inch	mm	inch
FN071-SDA.6K.V7P1	153 134	182	7.17	151	5.94	246	9.69	95	3.74	703	27.68
FN071-ADA.6F.V7P1	153 142	162	6.38	151	5.94	226	8.90	95	3.74	703	27.68
FN071-NDA.6F.V7P1	153 150	162	6.38	151	5.94	226	8.90	95	3.74	703	27.68

FE2owlet

FN071- DK.6 .V7P1

Airflow direction	V
Design	K
Material of impeller	Aluminium

**FN
071**

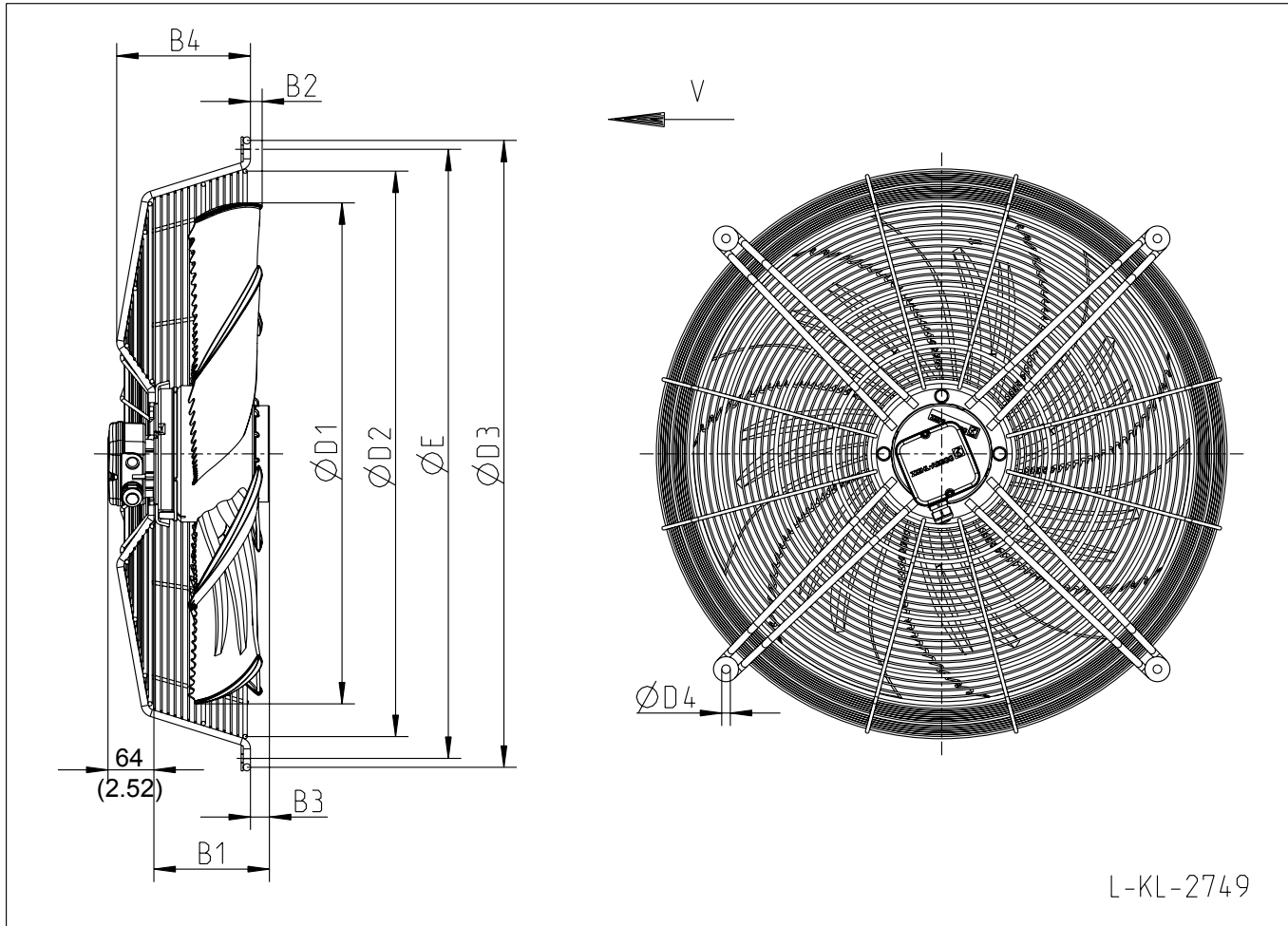

L-KL-2749

Type	Article no.	B1		B2		B3		B4		D1		D2		D3		E	
		mm	inch	mm	inch	mm	inch	mm	inch	mm	inch	mm	inch	mm	inch		
FN071-SDK.6K.V7P1	153 135	182	7.17	16	0.63	47	1.85	187	7.36	703	27.68	786	30.94	888	34.96	853	33.58
FN071-ADK.6F.V7P1	153 143	162	6.38	16	0.63	27	1.06	187	7.36	703	27.68	786	30.94	888	34.96	853	33.58
FN071-NDK.6F.V7P1	153 151	162	6.38	16	0.63	27	1.06	187	7.36	703	27.68	786	30.94	888	34.96	853	33.58

*) on request

FE2owlet

FN071- DS.6 .V7P1

Airflow direction	V
Design	S
Material of impeller	Aluminium

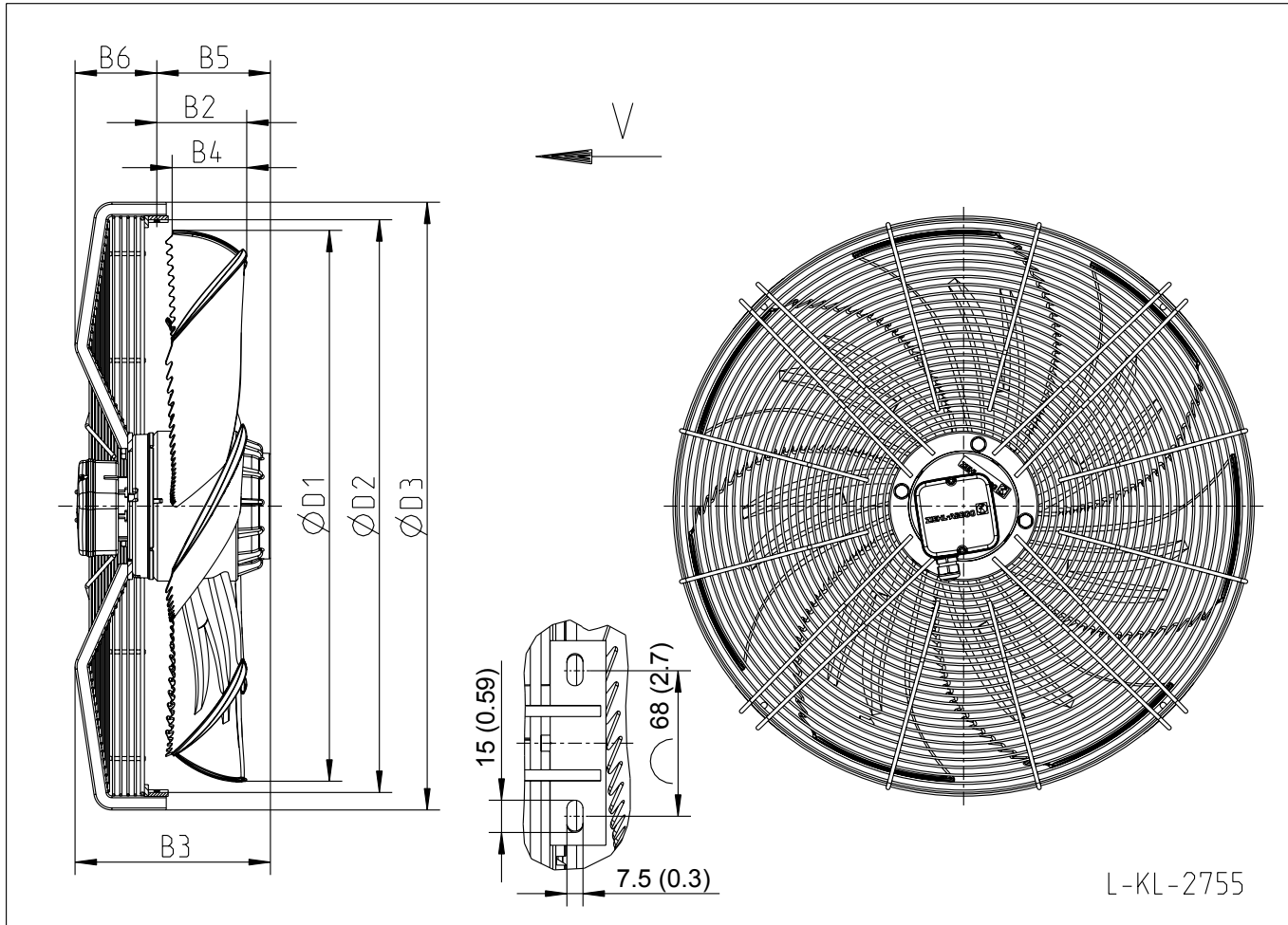

**FN
071**

L-KL-2755

Type	Article no.	B2		B3		B4		B5		B6		D1		D2		D3	
		mm	inch	mm	inch	mm	inch	mm	inch	mm	inch	mm	inch	mm	inch	mm	inch
FN071-SDS.6K.V7P1	153 137	114	4.49	246	9.69	95	3.74	145	5.71	104	4.09	703	27.68	730	28.74	774	30.47
FN071-ADS.6F.V7P1	153 145	114	4.49	226	8.90	95	3.74	125	4.92	104	4.09	703	27.68	730	28.74	774	30.47
FN071-NDS.6F.V7P1	153 153	114	4.49	226	8.90	95	3.74	125	4.92	104	4.09	703	27.68	730	28.74	774	30.47

FE2owlet

FN071- _DQ.6_.V7P1

Airflow direction	V
Design	Q
Material of impeller	Aluminium

**FN
071**

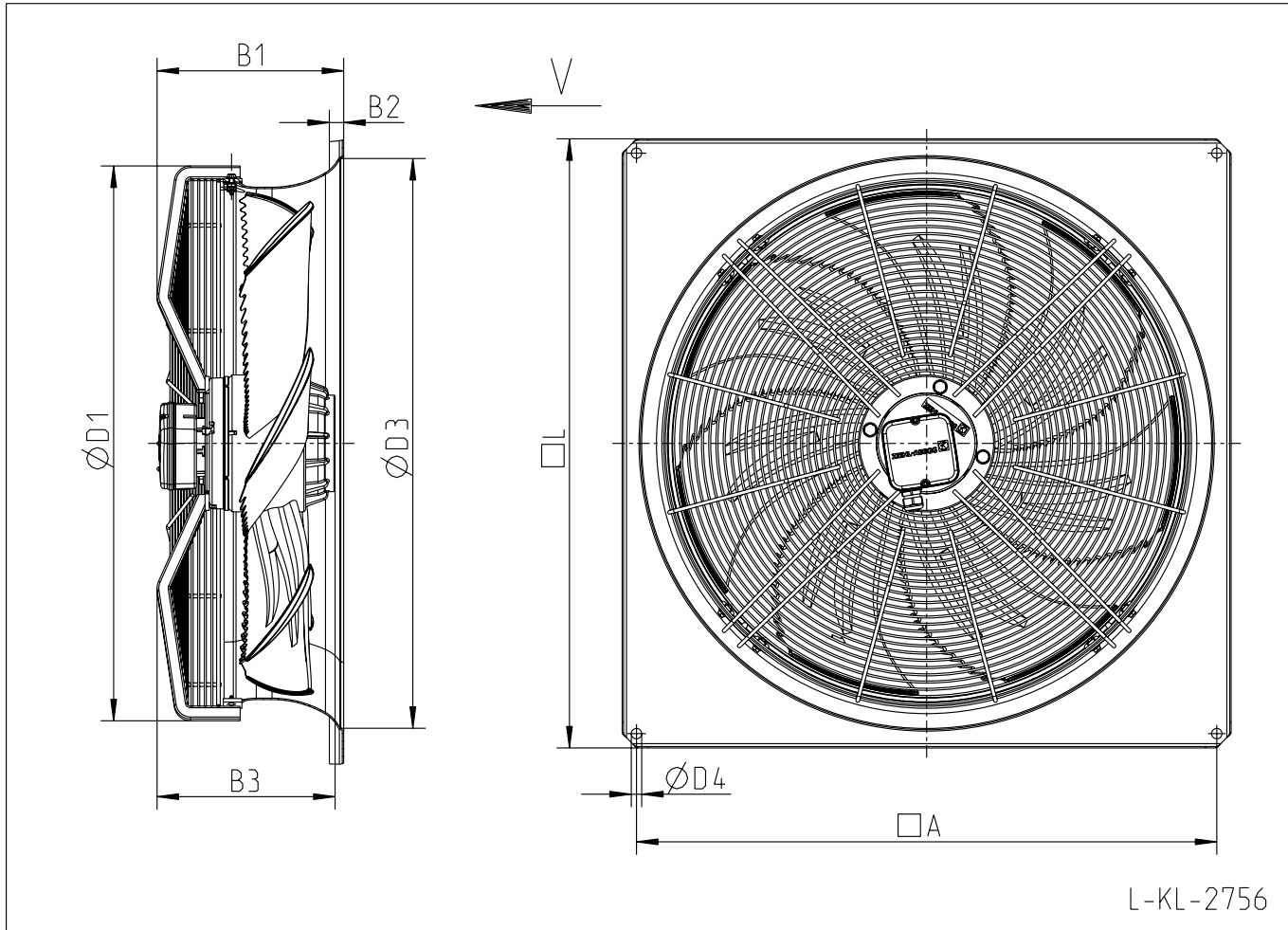

L-KL-2756

Type	Article no.	A		B2		B1		D1		D3		D4		L	
		mm	inch	mm	inch	mm	inch	mm	inch	mm	inch	mm	inch	mm	inch
FN071-SDQ.6K.V7P1	153 136	810	31.89	20	0.79	261	10.28	774	30.47	795	31.30	14.5	0.57	850	33.46
FN071-ADQ.6F.V7P1	153 144	810	31.89	20	0.79	261	10.28	774	30.47	795	31.30	14.5	0.57	850	33.46
FN071-NDQ.6F.V7P1	153 152	810	31.89	20	0.79	261	10.28	774	30.47	795	31.30	14.5	0.57	850	33.46

FE2owlet

FN071- DF.6 .V7P1

Airflow direction	V
Design	F
Material of impeller	Aluminium

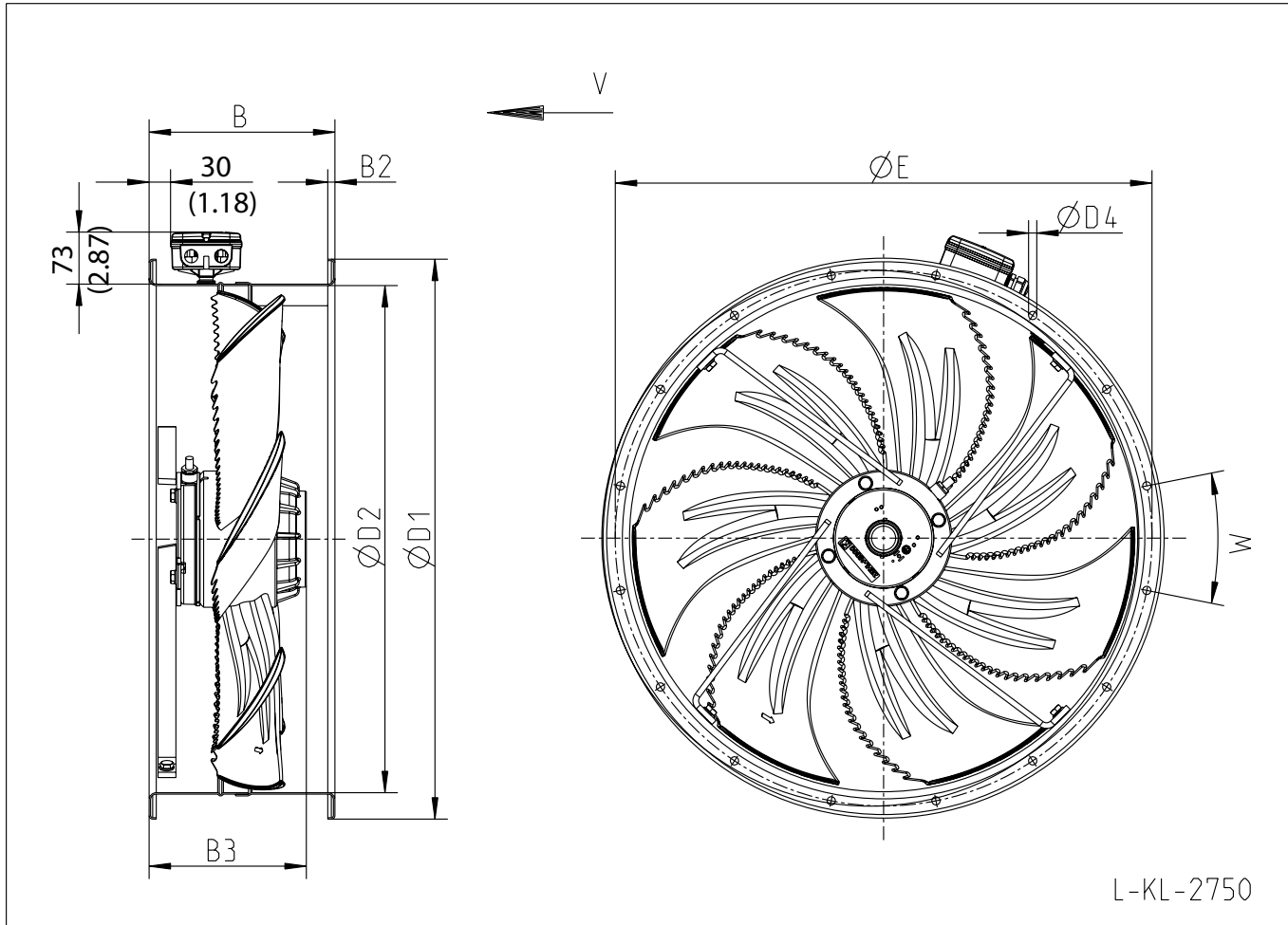

**FN
071**

L-KL-2750

Type	Article no.	B		B2		B3		D1		D2		D4		E		W
		mm	inch	mm	inch	mm	inch	mm	inch	mm	inch	mm	inch			
FN071-SDF.6K.V7P1	153 138	260	10.24	10	0.39	220	8.66	785	30.91	711	27.99	11.5	0.45	751	29.57	16x22.5
FN071-ADF.6F.V7P1	153 146	260	10.24	10	0.39	200	7.87	785	30.91	711	27.99	11.5	0.45	751	29.57	16x22.5
FN071-NDF.6F.V7P1	153 154	260	10.24	10	0.39	200	7.87	785	30.91	711	27.99	11.5	0.45	751	29.57	16x22.5

FN
071